

KT●●●●ER●●●

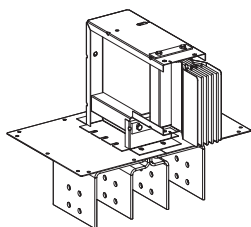
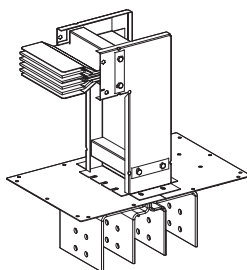
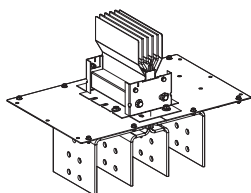

<p><b>PLEASE NOTE</b> Electrical equipment should be installed, operated, serviced, and maintained only by qualified personnel. No responsibility is assumed by Schneider Electric for any consequences arising out of the use of this material.</p>	<p><b>REMARQUE IMPORTANTE</b> L'installation, l'utilisation, la réparation et la maintenance des équipements électriques doivent être assurées par du personnel qualifié uniquement. Schneider Electric décline toute responsabilité quant aux conséquences de l'utilisation de cet appareil.</p>
<p><b>TENGA EN CUENTA</b> La instalación, manejo, puesta en servicio y mantenimiento de equipos eléctricos deberán ser realizados sólo por personal cualificado. Schneider Electric no se hace responsable de ninguna de las consecuencias del uso de este material.</p>	<p><b>BITTE BEACHTEN</b> Elektrische Geräte dürfen nur von Fachpersonal installiert, betrieben, bedient und gewartet werden. Schneider Electric haftet nicht für Schäden, die durch die Verwendung dieses Materials entstehen.</p>
<p><b>NOTA</b> Manutenzione, riparazione, installazione e uso delle apparecchiature elettriche si devono affidare solo a personale qualificato. Schneider Electric non si assume alcuna responsabilità per qualsiasi conseguenza derivante dall'uso di questi prodotti.</p>	<p><b>NOTA</b> A instalação, utilização e manutenção do equipamento eléctrico devem ser efectuadas exclusivamente por pessoal qualificado. A Schneider Electric não assume qualquer responsabilidade pelas consequências resultantes da utilização deste material.</p>
<p><b>请注意</b> 电气设备的安装、操作、维修和维护工作仅限于合格人员执行。Schneider Electric 不承担由于使用本资料所引起的任何后果。</p>	<p><b>ОБРАТИТЕ ВНИМАНИЕ</b> Электрическое оборудование должно обслуживаться квалифицированным персоналом. Компания Schneider Electric не несет ответственности за последствия, связанные с использованием данной документации. Данная документация не предназначена для использования в качестве руководства людьми, не прошедшими какого-либо обучения.</p>

<p><b>⚠ ⚠ DANGER / DANGER / PELIGRO / GEFAHR / PERICOLO / PERIGO / 危险 / ОПАСНОСТЬ</b></p>	
<p><b>HAZARD OF ELECTRIC SHOCK, EXPLOSION, OR ARC FLASH</b> Disconnect all power before servicing equipment. <b>Failure to follow these instructions will result in death or serious injury.</b></p>	<p><b>RISQUE D'ÉLECTROCUTION, D'EXPLOSION OU D'ECLAIR D'ARC ELECTRIQUE</b> Coupez toutes les alimentations avant de travailler sur cet appareil. <b>Si ces directives ne sont pas respectées, cela entraînera la mort ou des blessures graves.</b></p>
<p><b>PELIGRO DE DESCARGA ELÉCTRICA, EXPLOSIÓN O DESTELLO POR ARQUEO</b> Desconecte todas las alimentaciones antes de manipular el producto. <b>El incumplimiento de estas instrucciones podrá causar la muerte o lesiones serias.</b></p>	<p><b>GEFAHR VON ELEKTRISCHEM SCHLAG, EXPLOSION ODER LICHTBOGEN</b> Vor dem Arbeiten am Gerät alle Spannungsversorgungen abschalten. <b>Die Nichtbeachtung dieser Anweisungen führt zu Tod oder schweren Verletzungen.</b></p>
<p><b>RISCHIO DI FOLGORAZIONE, ESPLOSIONI O ARCO ELETTRICO</b> Scollegare l'apparecchiatura da tutti i circuiti di alimentazione prima di qualsiasi intervento. <b>Il mancato rispetto di queste istruzioni provocherà morte o gravi infortuni.</b></p>	<p><b>RISCO DE ELECTROCUSSÃO, DE EXPLOÇÃO, OU DE ARCO ELÉTRICO</b> Desconecte todas as alimentações antes de manipular o produto. <b>A não observância destas instruções resultará em morte, ou ferimentos graves.</b></p>
<p><b>电击、爆炸或电弧闪光危险</b> 在此电力设备上工作时，请先切断所有电源。不遵循上述说明将导致人员伤亡。</p>	<p><b>Опасность поражения электрическим током, опасность взрыва или вспышки дуги.</b> Перед обслуживанием или ремонтом убедитесь, что питание отключено. <b>Несоблюдение этих инструкций приведет к смерти или серьезной травме.</b></p>

**Schneider Electric Industries SAS**  
35, rue Joseph Monier  
CS 30323  
F - 92506 Rueil Malmaison Cedex

**Schneider Electric Limited**  
Stafford Park 5  
Telford, TF3 3BL  
United Kingdom  
www.se.com/uk



**Уполномоченный поставщик в РФ:**  
**АО «Шнейдер Электрик»**  
Адрес: 127018, г. Москва, ул.  
Двинцев, д. 12, корп. 1, тел. +7 (495) 777 99 88,  
факс: +7 (495) 777 99 94, 8-800-200-6446  
www.se.com/ru



**▲ CAUTION / ATTENTION / ATENCIÓN / VORSICHT /  
ATTENZIONE / CUIDADO / 小心 / ВНИМАНИЕ**



**RISK OF CUTTING**

- Store the products in a dedicated and marked area.
  - Wear personal protective equipment when handling and installing the products (gloves, long sleeved jacket, trousers, safety shoes, helmet, safety glasses).
- Failure to follow these instructions can result in injury or equipment damage.**

**RISQUE DE COUPURE**

- Stockez les produits dans une zone dédiée et balisée.
  - Utilisez des équipements individuels de protection lors de la manipulation et de l'installation des produits (gants, veste à manches longues, pantalon, chaussures de sécurité, casque, lunettes de sécurité).
- Le non-respect de ces instructions peut provoquer des blessures ou des dommages matériels.**



**RIESGO DE CORTES**

- Almacene los productos en áreas específicas y señalizadas para ello.
  - Utilice un equipo de protección personal cuando manipule e instale los productos (guantes, chaqueta de manga larga, pantalones, zapatos de seguridad, casco y gafas de seguridad).
- Si no se siguen estas instrucciones pueden producirse lesiones personales o daños en el equipo.**

**GEFÄHRDUNG DURCH SCHNEIDEN**

- Lagern Sie die Produkte im dafür vorgesehenen, gekennzeichneten Bereich.
  - Tragen Sie Schutzkleidung bei der Handhabung und Installation der Produkte (Handschuhe, Jacke mit langen Ärmeln, Hosen, Sicherheitsschuhe, Helm, Schutzbrille).
- Die Nichtbeachtung dieser Anweisungen kann Verletzungen oder Sachschäden zur Folge haben.**



**RISCHIO DI TAGLIO**

- Conservare i prodotti in un'area dedicata e contrassegnata.
  - Indossare protezioni individuali adeguate per la manipolazione e l'installazione dei prodotti (guanti, giacche a manica lunga, pantaloni, calzature antinfortunistiche, elmetto, occhiali protettivi).
- Il mancato rispetto di queste istruzioni può provocare infortuni o danni alle apparecchiature.**

**RISCO DE CORTE**

- Armezen os produtos numa área dedicada e assinalada.
  - Use equipamento de protecção pessoal quando manusear e instalar os produtos (luvas, casaco de mangas compridas, calças, calçado de segurança, capacete, óculos de protecção).
- A não observância destas instruções pode provocar ferimentos pessoais, ou danos no equipamento.**



**割伤危险**

- 请在标明的专门区域存储本产品。
  - 搬运和安装产品时请穿戴个人防护装备（手套、长袖夹克、长裤、安全鞋、头盔、护目镜）。
- 不遵循上述说明可能导致人身伤害或设备损坏。**

**РИСК ПОРЕЗОВ**

- Храните изделия в специальном месте с маркировкой.
  - Надевайте средства персональной защиты при погрузке-разгрузке и установке изделий (перчатки, куртку с длинными рукавами, брюки, защитную обувь, каску, защитные очки).
- Несоблюдение этих инструкций может привести к травме или повреждению оборудования.**



<p>The product's manufacture date is coded as PP-YYYY-MM-DD, where:</p> <ul style="list-style-type: none"> <li>■ PP: plant code</li> <li>■ YYYY: year of manufacture</li> <li>■ MM: month of manufacture</li> <li>■ DD: day of manufacture</li> </ul> <p>Eg: RX-2014-12-01 = product manufactured at plant RX on December 1 2014.</p>	<p>La date de fabrication du produit est codée sous la forme PP-YYYY-MM-DD, où:</p> <ul style="list-style-type: none"> <li>■ PP: code de l'usine</li> <li>■ YYYY: année de fabrication</li> <li>■ MM: mois de fabrication</li> <li>■ DD: jour de fabrication</li> </ul> <p>Ex: RX-2014-12-01 = produit fabriqué le 1 décembre 2014 par l'usine RX.</p>
<p>La fecha fabricación del producto está codificada como PP-YYYY-MM-DD, donde:</p> <ul style="list-style-type: none"> <li>■ PP: código de planta</li> <li>■ YYYY: año de fabricación</li> <li>■ MM: mes de fabricación</li> <li>■ DD: día de fabricación</li> </ul> <p>Ej: RX-2014-12-01 = producto fabricado en la planta RX el 1 de diciembre de 2014.</p>	<p>Das Herstellungsdatum des Produkts weist folgendes Format auf: PP-YYYY-MM-DD. Hierbei gilt Folgendes:</p> <ul style="list-style-type: none"> <li>■ PP: Code der Produktionsstätte</li> <li>■ YYYY: Herstellungsjahr</li> <li>■ MM: Herstellungsmonat</li> <li>■ DD: Herstellungstag</li> </ul> <p>Z. B.: RX-2014-12-01 = Herstellung des Produktes am Standort RX am 1. Dezember 2014.</p>
<p>La data di costruzione del prodotto è codificata come segue PP-YYYY-MM-DD, dove:</p> <ul style="list-style-type: none"> <li>■ PP: codice stabilimento</li> <li>■ YYYY: anno di fabbricazione</li> <li>■ MM: mese di produzione</li> <li>■ DD: giorno di produzione</li> </ul> <p>Ad es.: RX-2014-12-01 = prodotto realizzato nell'impianto RX il 1 dicembre 2014.</p>	<p>A data de fabrico do produto está codificada como PP-YYYY-MM-DD, sendo que:</p> <ul style="list-style-type: none"> <li>■ PP: código da fábrica</li> <li>■ YYYY: ano de fabrico</li> <li>■ MM: mês de fabrico</li> <li>■ DD: dia de fabrico</li> </ul> <p>Ex: RX-2014-12-01 = produto fabricado na fábrica RX a 1 de Dezembro de 1</p>
<p>产品制造日期编码为 PP-YYYY-MM-DD，其中：</p> <ul style="list-style-type: none"> <li>■ PP: 工厂代码</li> <li>■ YYYY: 制造年份</li> <li>■ MM: 制造月份</li> <li>■ DD: 制造日期</li> </ul> <p>例如: RX-2014-12-01 = 表示产品由 RX 工厂于 2014 年 12 月 1 日制造。</p>	<p>Дата производства продукта указана в виде кода PP-YYYY-MM-DD, где:</p> <ul style="list-style-type: none"> <li>■ PP: код завода;</li> <li>■ YYYY: год производства;</li> <li>■ MM: месяц производства</li> <li>■ DD: число производства</li> </ul> <p>Пример: RX-2014-12-01 = изделие изготовлено на заводе RX 1 декабря 2014 г.</p>



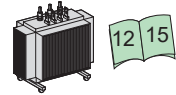
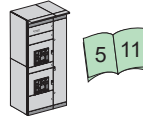
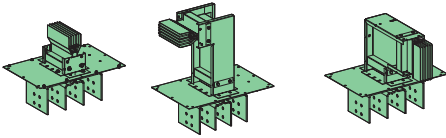

KTA1000	KTA1250	KTA1600	KTA2000	KTA2500	KTA3200	KTA4000
KTC1350	KTC1600	KTC2000	KTC2500	KTC3200	KTC4000	KTC5000
 100 230	 120 230	 160 230	 200 350	 240 350	 320 510	 400 510

KTA	KTC	Y	X mini
1000 A...1250 A	1000 A...1600 A	190	400
1600 A...2500 A	2000 A...3200 A	310	400
3200 A...4000 A	4000 A...5000 A	470	600

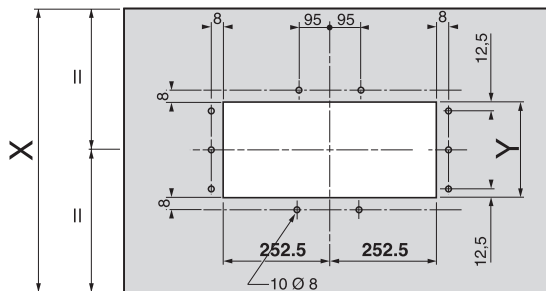
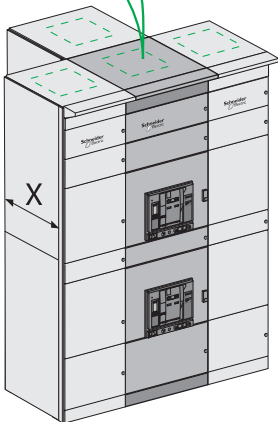

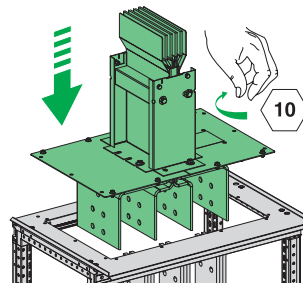
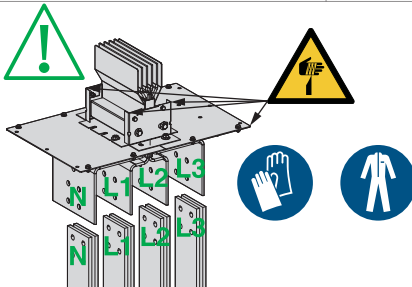
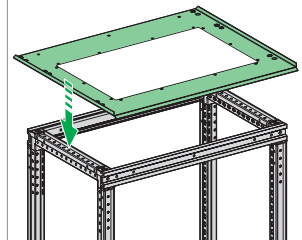
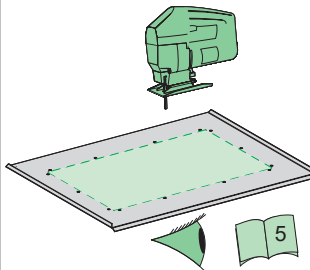
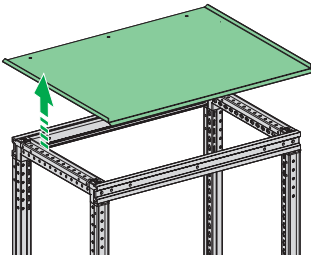
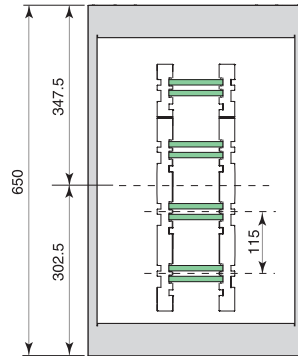
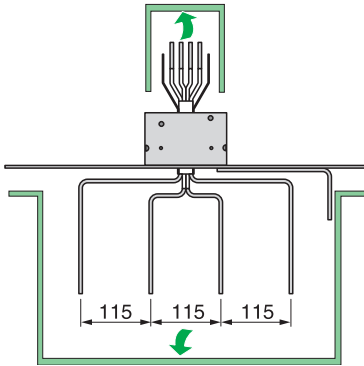
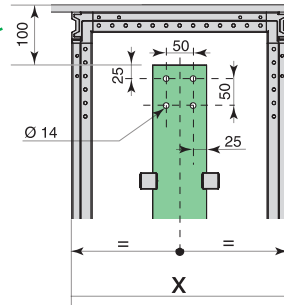
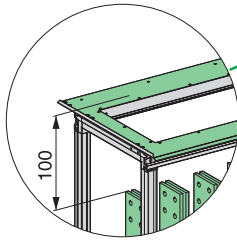
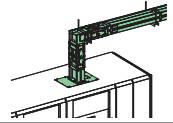

KTA1000.....4000 A  
KTC1350.....5000 A

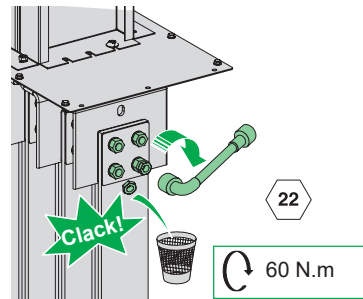
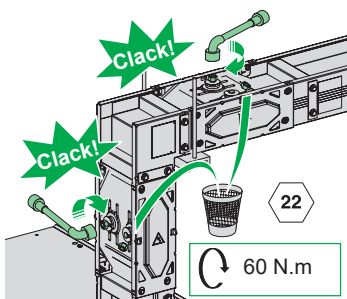
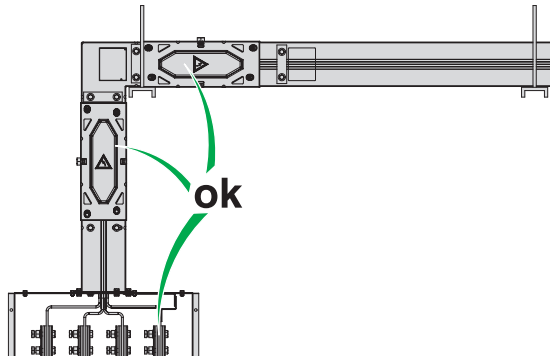
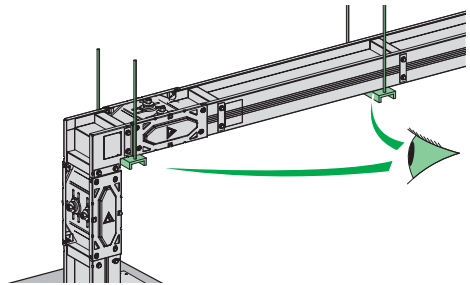
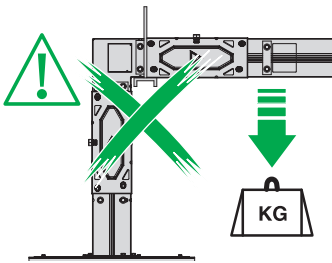
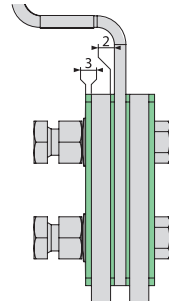
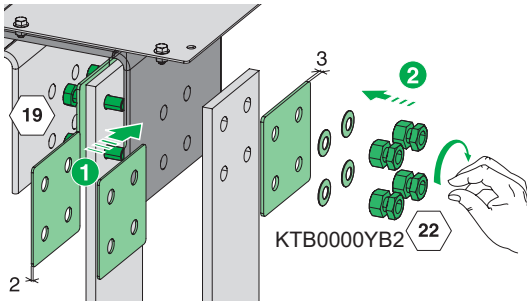
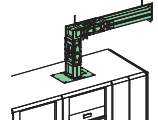

**KTA1000.....4000 A**  
**KTC1350.....5000 A**

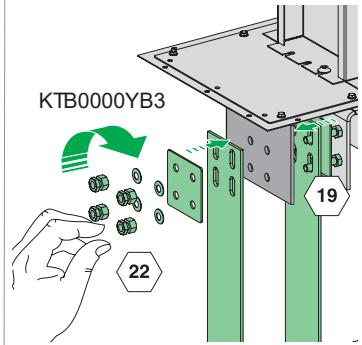
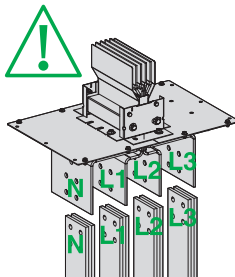
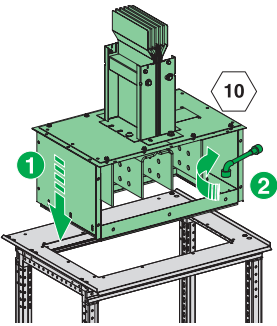
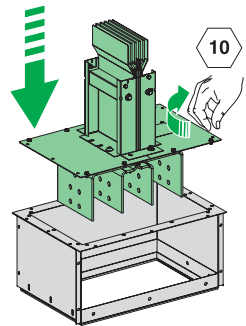
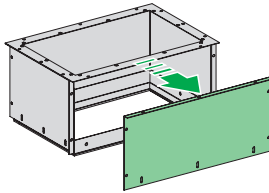
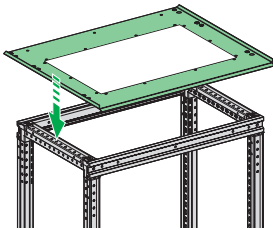
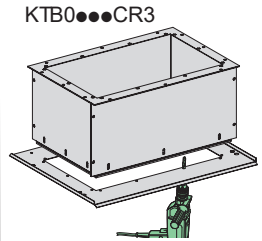
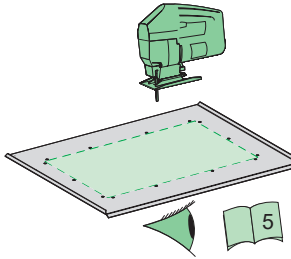
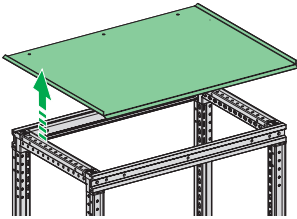
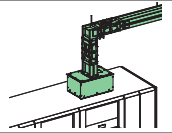

1 1	1 2	2 2	2 3	3 3
KTA1000...1600	KTA2000...2500	KTA3200	KTA4000	KTC5000
KTC1350...1600	KTC2000...2500	KTC3200	KTC4000	

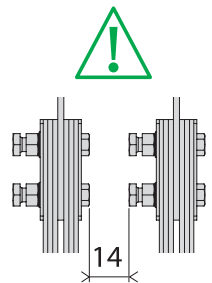

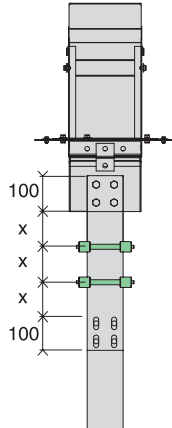
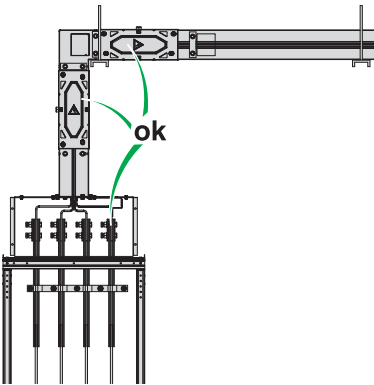
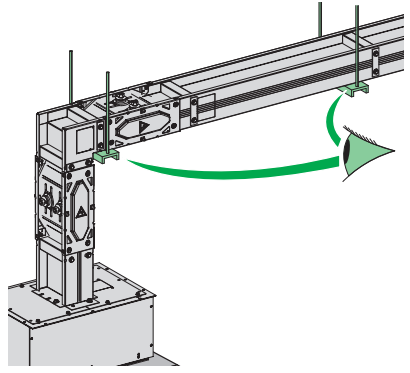
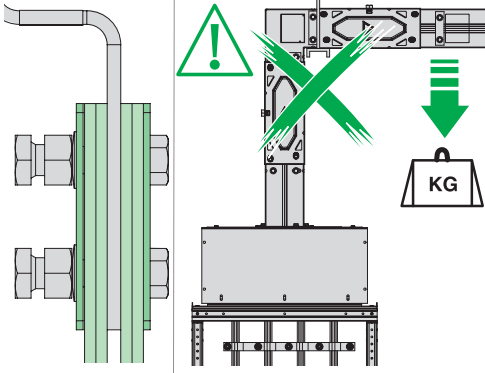
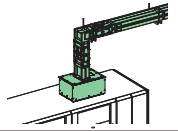

$I_{cw}$ (1s)	X
$I_{cw} \leq 43kA$	400
$43kA < I_{cw} \leq 50kA$	225
$50kA < I_{cw} \leq 100kA$	150

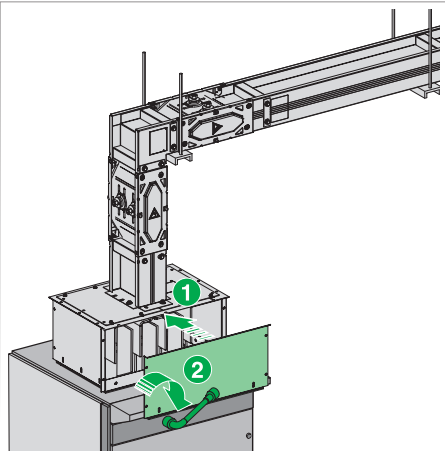
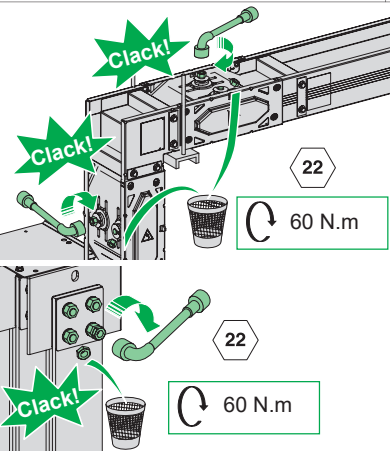

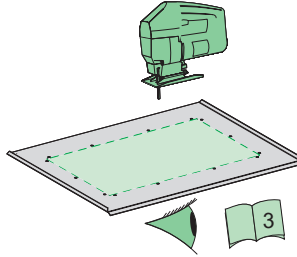
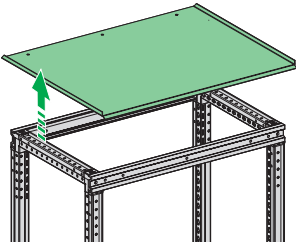
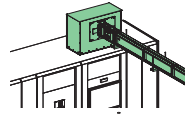

KTB0...CR1

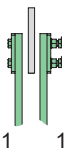
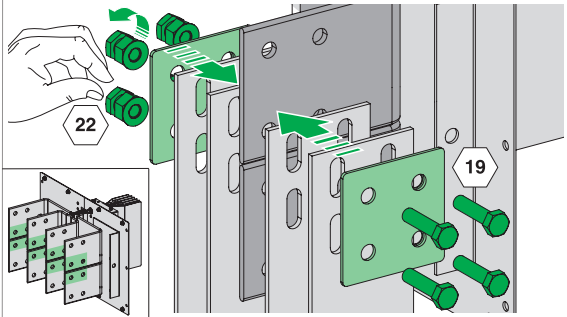
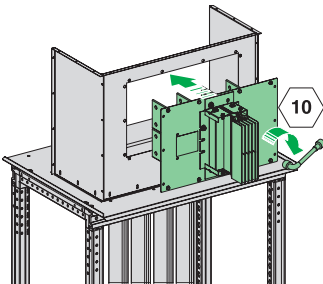
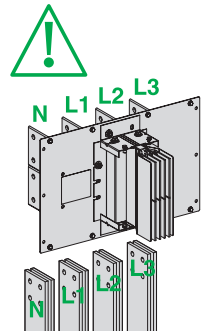
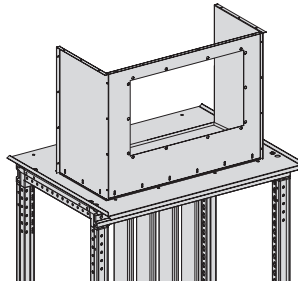
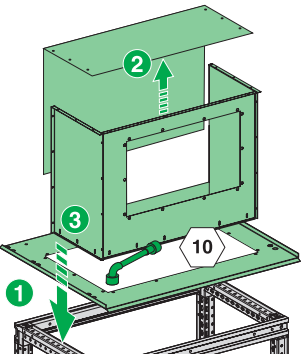
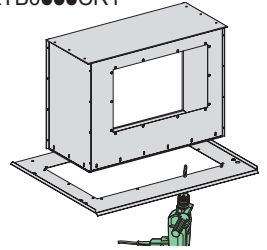

1 1

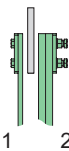

1 2

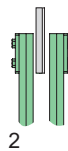

2 2

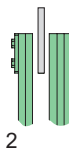

2 3

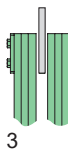

3 3

KTA1000...1600

KTA2000...2500

KTA3200

KTA4000

KTC5000

KTC1350...1600

KTC2000...2500

KTC3200

KTC4000

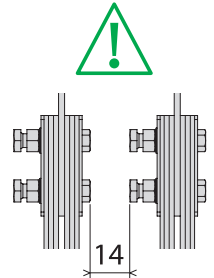

14

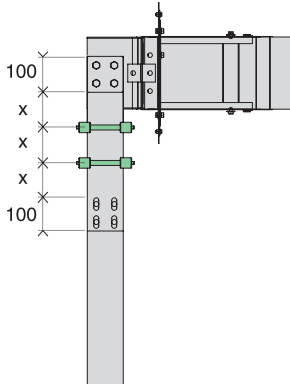
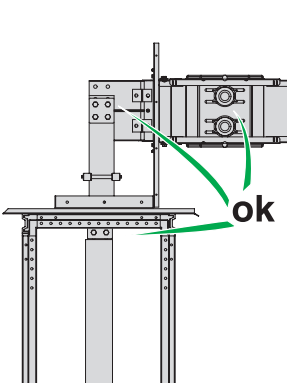
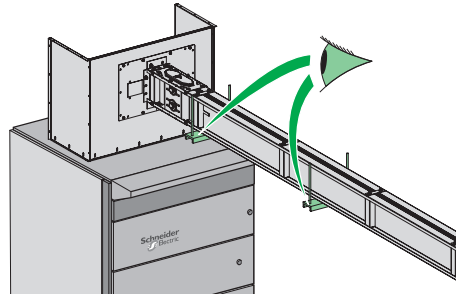
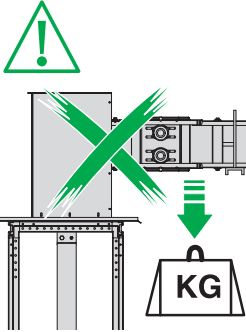
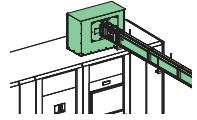

$I_{cw}$ (1s)	x
$I_{cw} \leq 43kA$	400
$43kA < I_{cw} \leq 50kA$	225
$50kA < I_{cw} \leq 100kA$	150

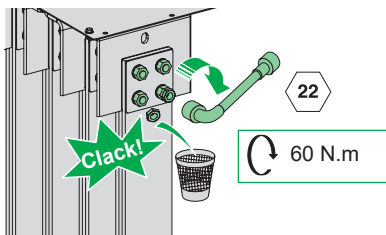
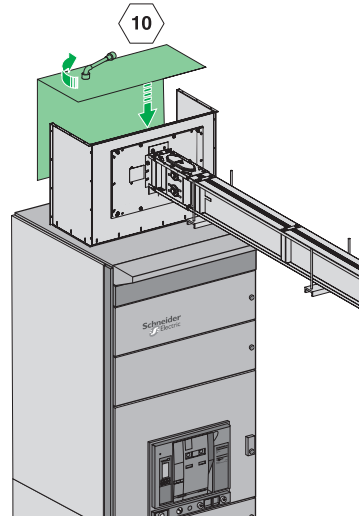
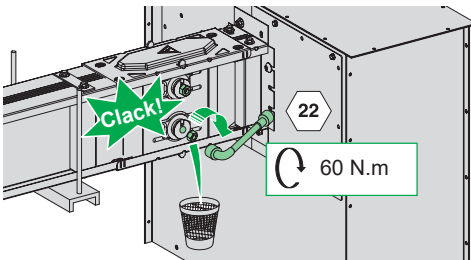

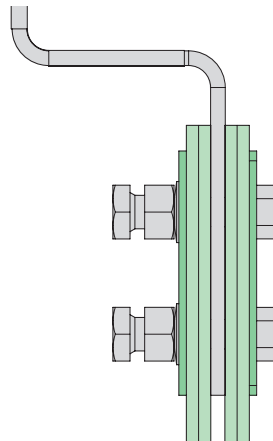
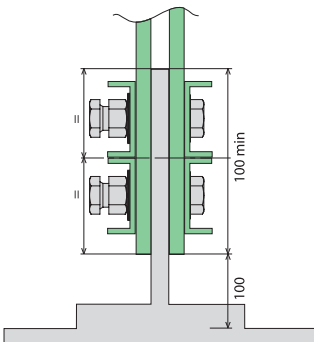
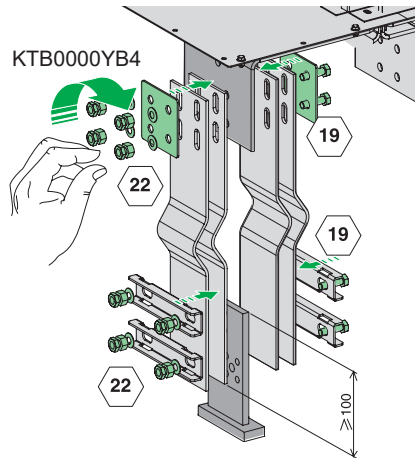
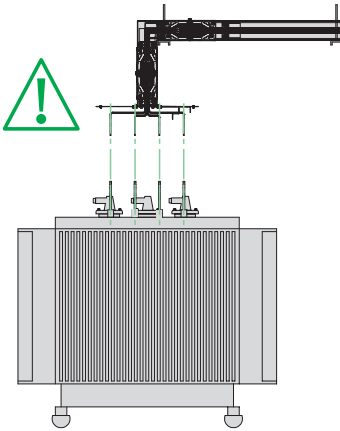
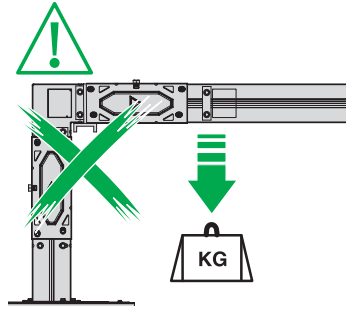
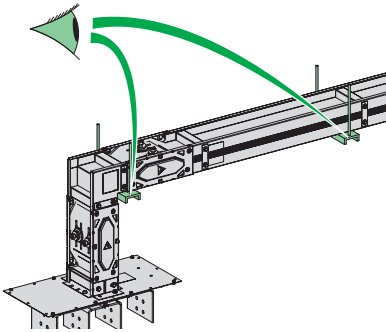
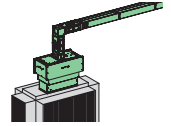



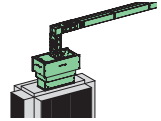

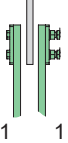
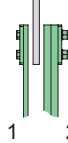
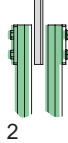
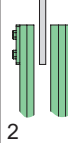
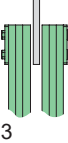
				
1 1	1 2	2 2	2 3	3 3
KTA1000...1600 KTC1350...1600	KTA2000...2500 KTC2000...2500	KTA3200 KTC3200	KTA4000 KTC4000	KTC5000

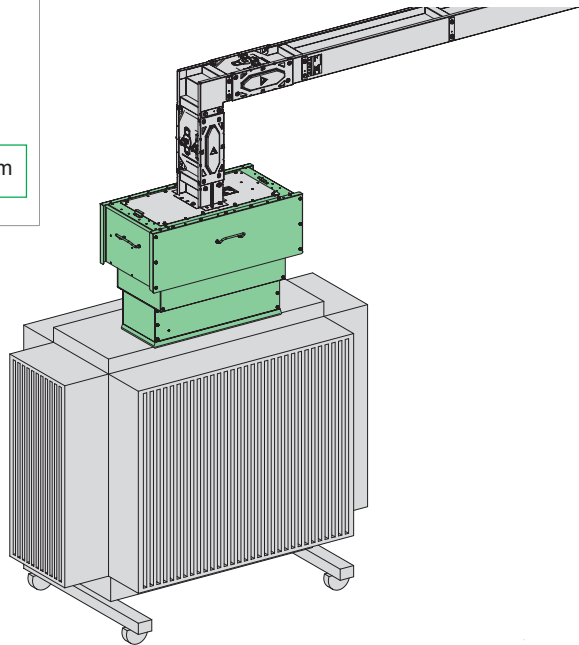
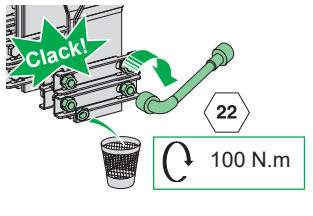
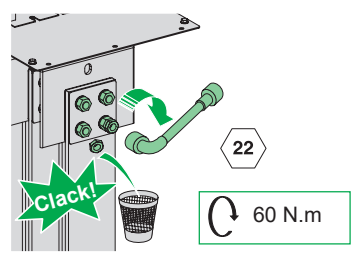
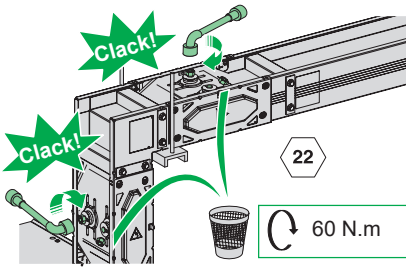
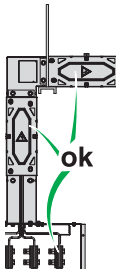
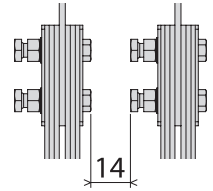

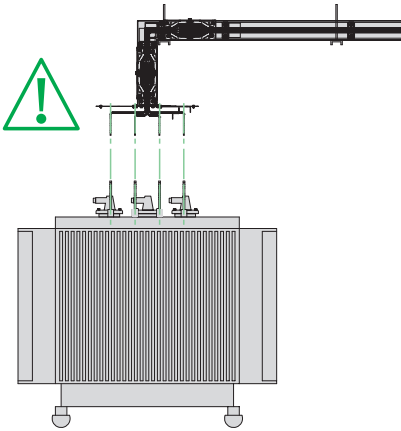
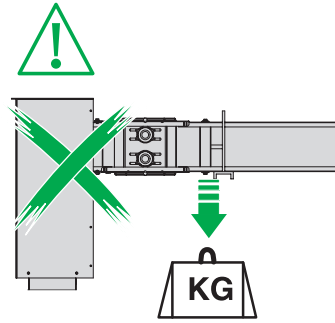
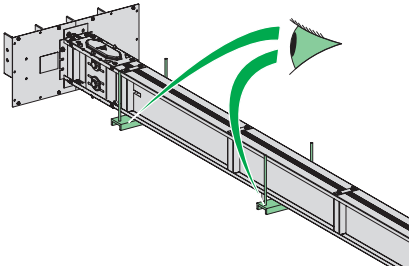
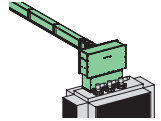

KTB0000YB4

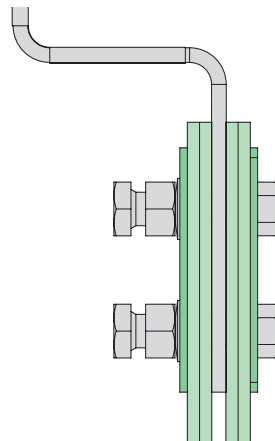
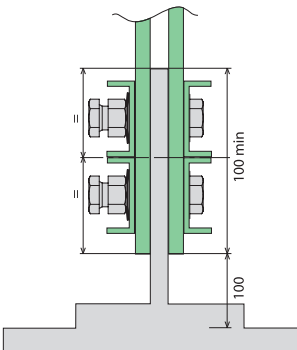
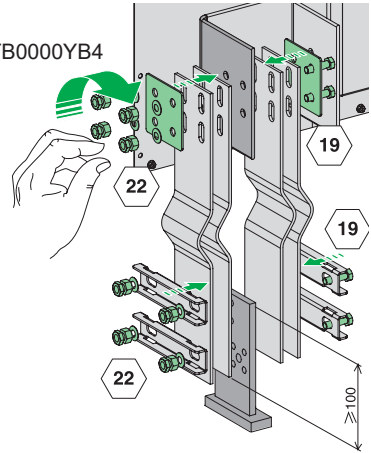

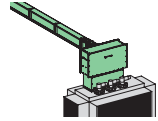

1 1	1 2	2 2	2 3	3 3
KTA1000...1600 KTC1350...1600	KTA2000...2500 KTC2000...2500	KTA3200 KTC3200	KTA4000 KTC4000	KTC5000

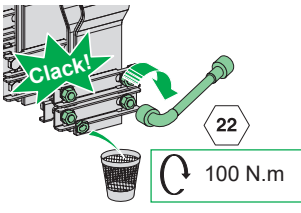
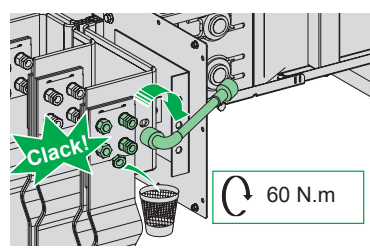
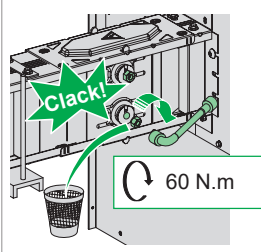
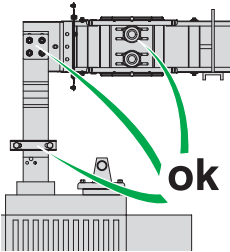
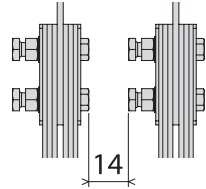

IS AAV32050

